

Gree Split AC - KNX Gateway

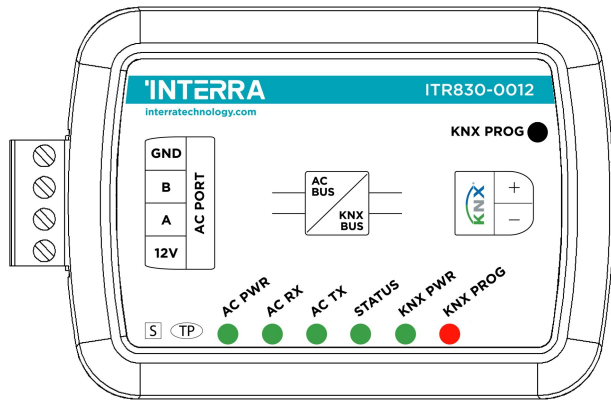

Product Code	ITR830-0012
Power Supply	KNX Power Supply
Current Consumption	7 mA
Push Buttons	1 x KNX Programming Button
LED Indicators	1 x KNX Programming LED
Type of Protection	IP 20
Mode of Commissioning	S-Mode
Maximum Air Humidity	< 90 RH
Temperature Range	Operation (-10°C...70°C) Storage (-25°C...100°C)
Colour	Light Grey
Dimensions	88 x 62 x 27 mm (W x H x D)
Certification	KNX Certified
Configuration	Configuration with ETS

DESCRIPTION

ITR830-0012 is an air conditioner gateway used for monitoring and controlling all the functioning parameters of Gree air conditioners via the KNX bus line. Gree Split AC - KNX Gateway is compatible with models in split types categorized at compatibility list published by Interra.

Gree Split AC - KNX Gateway has an easy installation feature and can be installed inside the own AC indoor unit or a proper location away from the air conditioner, it connects one side directly to the electronic circuit of the AC indoor unit and in the other side directly to the KNX bus.

DIMENSIONS & CONNECTION DIAGRAM

- All values given in the device dimensions are millimetres.

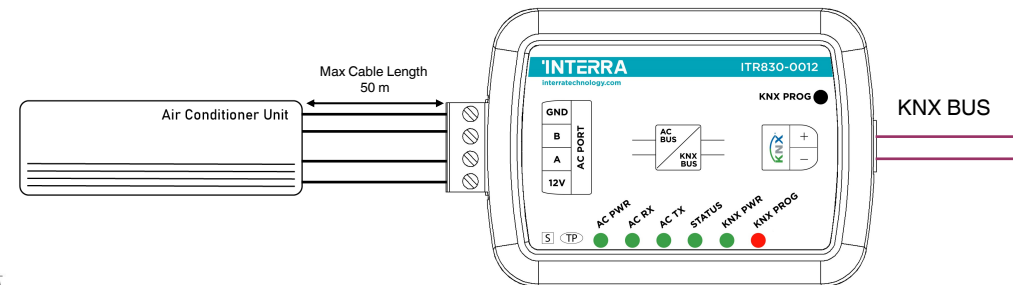
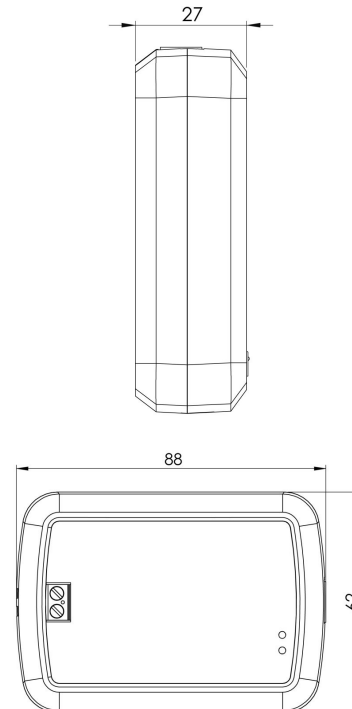

FUNCTIONS

- ITR830-0012 device provides complete bidirectional integration of Gree Split air conditioners with KNX bus.
- Includes 4 logical advanced parameters, each logical parameter have up to 4 inputs and can be configured as AND, OR & XOR.
- Includes 8 advanced converter parameters, each converter has four operations math calculations according to the input type.
- Logic and converter parameters can be used for energy savings, configurable scenes, temperature limits etc.
- The Gree air conditioner unit provides error notifications for errors that may occur in exceptional cases.